

Parts List			
ITEM	QTY	PART NUMBER	DESCRIPTION
1	2	150(200)K	1 1/2" & 2" CAM ARM
2	1	200G	2" Coupling Gasket
3	2	200P	CAM ARM PIN
4	1	150(200)D	DECAL (N/S)
5	1	200XD	2" FML CPLG X 2" NPT

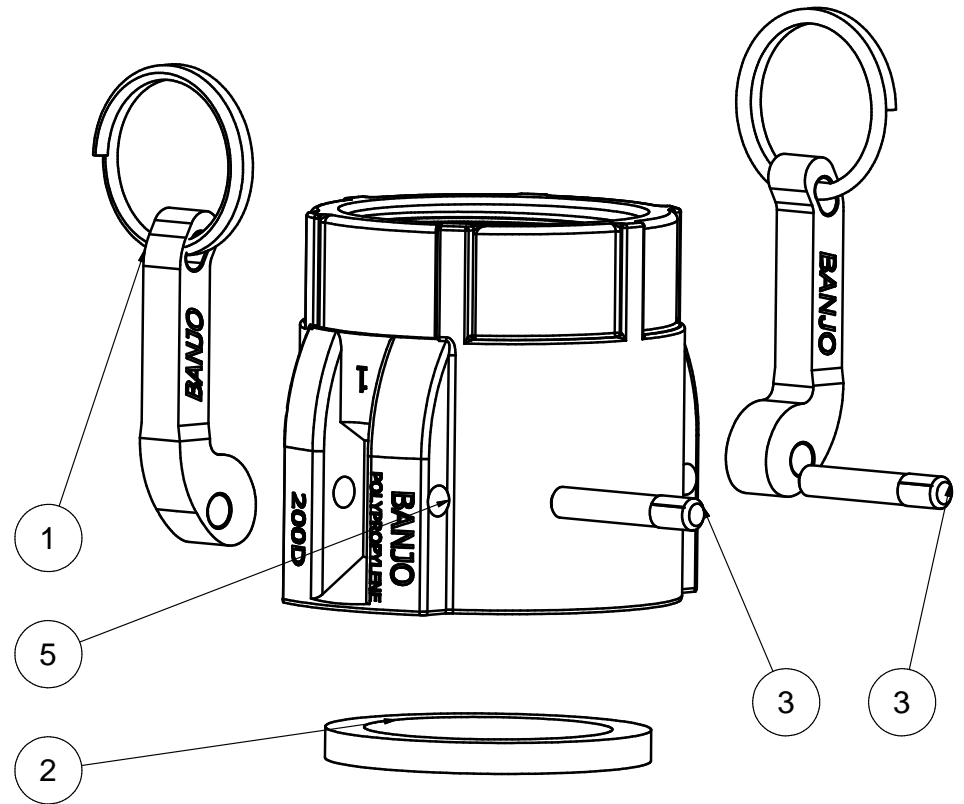

THIS DRAWING AND ALL INFORMATION CONTAINED THEREON ARE THE EXCLUSIVE PROPERTY OF BANJO CORPORATION.

UNLESS SPECIFICALLY NOTED, THIS DRAWING AND ITEMS SHOWN ON THIS DRAWING ARE SUBJECT TO CHANGE AT ANY TIME.

**BANJO**  
CORPORATION

BANJO CORPORATION  
150 BANJO DRIVE, CRAWFORDSVILLE, IN 47933  
WEB SITE: WWW.BANJOCORP.COM  
E-MAIL: BANJOSALES@IDEXCORP.COM

DESCRIPTION  
2" FEMALE COUPLER X 2" FEMALE NPT  
PART NUMBER  
200D